

SNC-02(C/V)-XX-10; SNC-03(C/V)-XX-20; SNC-03(C/V)-XX-30

Pump Dimensions

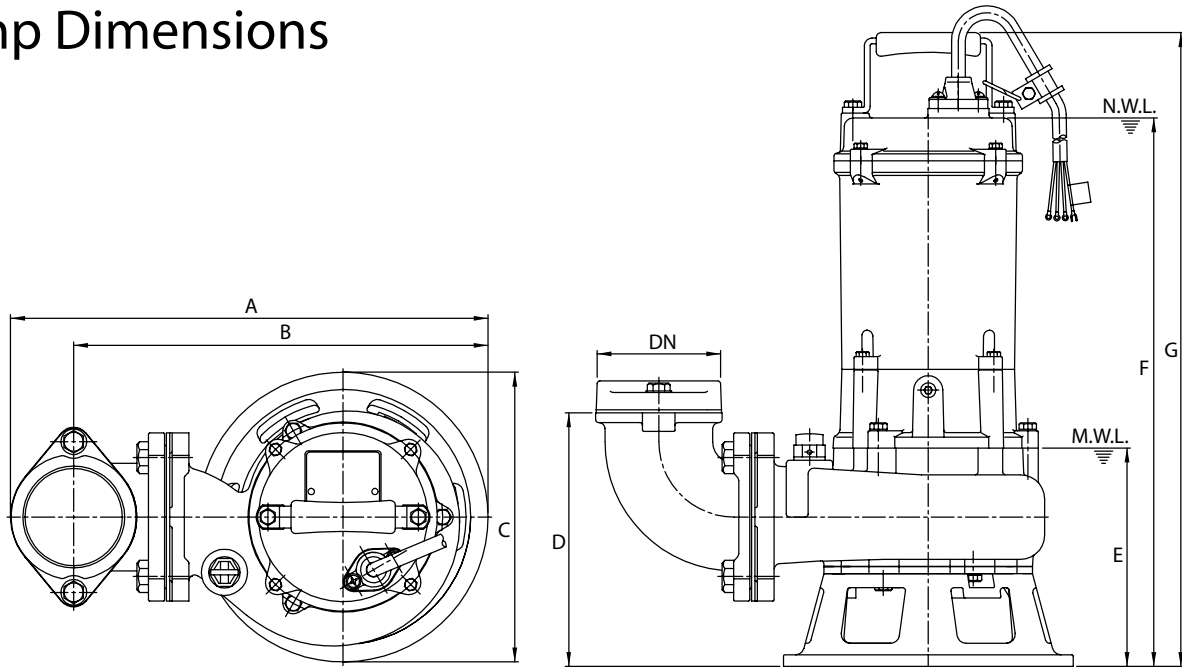

TYPE	DN	A	B	C	D	E	F	G
SNC-02(C/V)-XX-10	2	15.13	13.38	9.25	7.88	6.63	17.38(19.13)	19.75(20.63)
SNC-03(C/V)-XX-20	3	16.25	14.00	9.88	8.63	7.50	18.63(20.63)	21.50(23.50)
SNC-03(C/V)-XX-30	3	16.25	14.00	9.88	8.63	7.50	19.63	22.50

Single phase dimensions ()
N.W.L.: Normal water level
M.W.L.: Minimum water level

Easy Lift GRS - Guide Rail System Dimensions

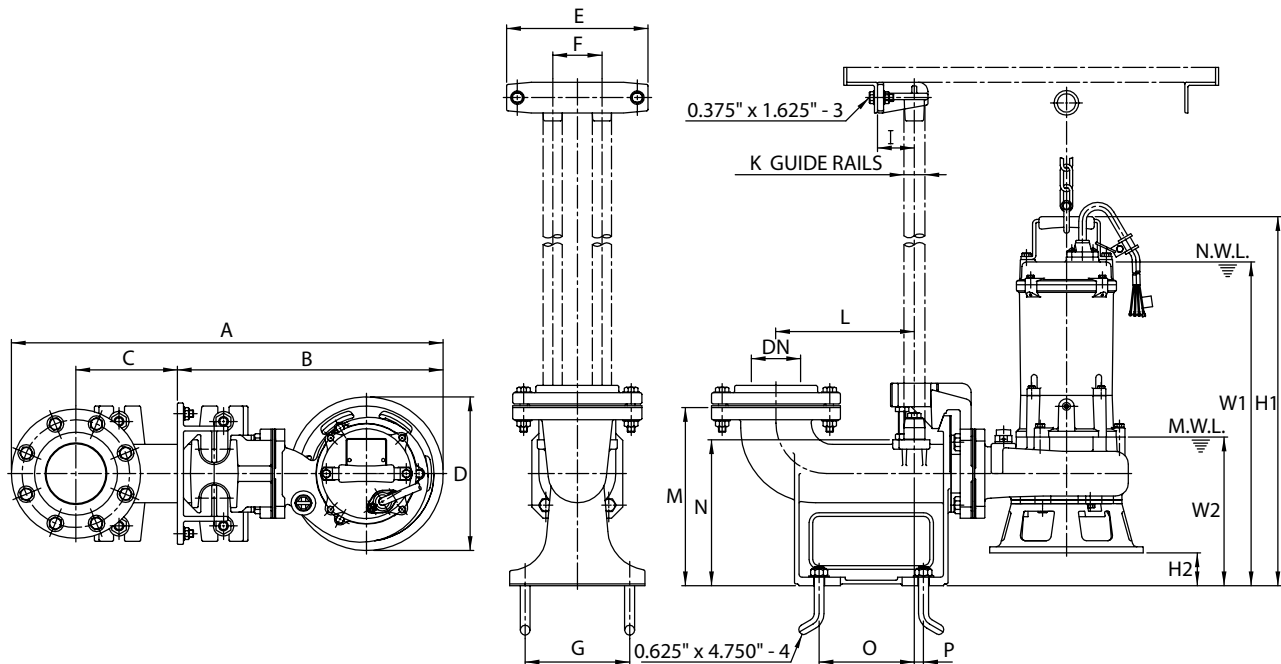

TYPE	DN	A	B	C	D	E	F	G	I	K	L	M	N	O	P	W1	W2	H1	H2
SNC-02(C/V)-XX-10	2	22.88	15.38	4.50	9.25	9.00	2.75	4.75	1.88	1.00	6.50	9.88	8.00	4.25	0.50	19.00(20.75)	8.38	20.25(22.13)	1.63
SNC-03(C/V)-XX-20	3	21.63	16.88	5.13	9.88	9.00	3.13	5.88	2.38	1.25	7.50	11.25	9.25	5.25	0.63	20.50(22.38)	9.25	23.38(25.38)	1.75
SNC-03(C/V)-XX-30	3	21.63	16.88	5.13	9.88	9.00	3.13	5.88	2.38	1.25	7.50	11.25	9.25	5.25	0.63	21.38	9.25	24.25	1.75

All dimensions are in inches unless otherwise noted.